

Ø19mm Submersible

DEPTH SENSOR

Pi994
Series



- Pressure Ranges 1mWC to 250mWC
- Small 19mm Diameter to suit 1" boreholes
- All Stainless Steel Construction
- Excellent Price/Performance Ratio
- Excellent Thermal Performance
- **3 YEAR WARRANTY**

Options Available

Customer Specific Ranges available on request
Alternative Cable Types
Improved Accuracy

DESCRIPTION

The Pi994I slimline submersible level transmitter is manufactured from Stainless Steel. The robust body and PVC cable with vent tube and strain wire provide a high integrity waterproof assembly suitable, as standard, to withstand the environmental pressures of up to 250mWG.

The Pi994I's slimline 19mm diameter body makes it suitable use in applications where space is at a premium. 1" observation pipes in ground water measurement applications are one example.

The Pi994I level transmitter offers rugged construction along with excellent long term stability and performance. To further support our claim of long term reliability we offer the product as standard with a 3 Year Warranty.

Transducer Specialists...

APPLIED MEASUREMENTS LIMITED

3 MERCURY HOUSE - CALLEVA PARK - ALDERMASTON - BERKSHIRE - RG7 8PN - UK

Tel: (+44) 0118 981 7339 Fax: (+44) 0118 981 9121 email: info@appmeas.co.uk Internet: www.appmeas.co.uk



SPECIFICATION

CHARACTERISTICS	Pi9941	UNITS
Pressure Ranges:	1, 1.6, 2.5, 4, 6, 10, 16, 25, 40, 60, 100, 160, 250	mWG
Operational Mode:	Vented Gauge	
Sensitivity (Rated Output):	4-20	mA
Zero Offset	1	±%FSO
Excitation Voltage:	12-36	VDC
Accuracy (Combined Error):	<0.4bar=0.25, >0.4bar=<0.175 (0.125% opt. >0.4bar)	% of Rated Output BFSL
Overpressure Capability:	150	% of Pressure Range
Burst Pressure:	200	% of Pressure Range
Temperature Range Operating:	-10 to +70	°C
Compensated:	<0.4bar=0 to +50, >1bar=-20 to +85	°C
Thermal Error Band:	<0.1bar=2, <0.25bar=1.5, <1bar=1, <1bar=0.75	±% of FSO
Media Compatibility:	Any Gas or Fluid compatible with Stainless Steel, Viton & PVC	
Environmental Protection:	IP68	
Weight:	Approx 100g without cable	

All dimensions in mm

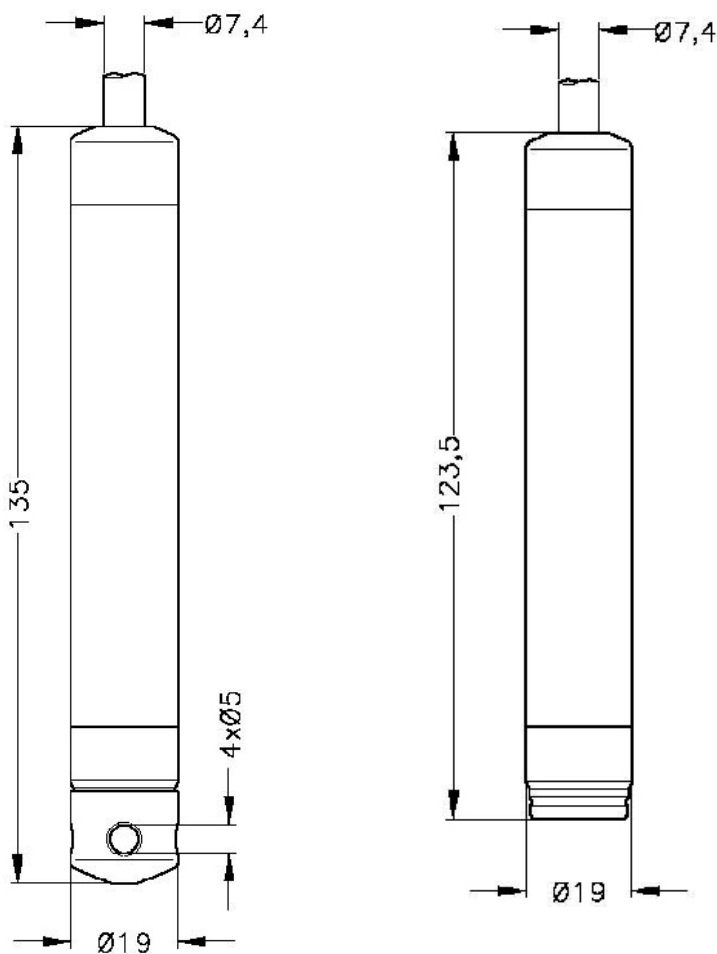

Issue 06/06



APPLIED MEASUREMENTS LIMITED

Continuous product development may result in minor changes to published specifications.